

U. S. NAVY EXPERIMENTAL DIVING UNIT  
AND  
U. S. NAVAL SCHOOL, DEEP SEA DIVERS  
U. S. NAVAL WEAPONS PLANT  
WASHINGTON 25, D. C.

COMMANDER N. E. NICKERSON, USN, OFFICER IN CHARGE

THE FACEPLATE - OCTOBER 1960

From the Officer in Charge:

Since the last issue of the Faceplate in January 1960, quite a few changes have taken place at both EDU and DSDS. Our personnel situation now appears to be somewhat stabilized. On 30 September, I relieved Commander McNicol as Officer in Charge. Captain M. K. Holler, (MC), USN continues as Senior Medical Officer. LCDR E. W. Carpenter has been detached from his duties as Assistant Officer in Charge of DSDS to the same duties at EDU, while LCDR G. E. Enright has reported from USS PENGUIN (ASR-12) as Assistant Officer in Charge of DSDS. Other personnel changes will be covered in Departmental Sections.

Starting with this issue, we intend to use the insignia of the various diving activities throughout the Navy as cover illustrations. This issue has the EDU insignia and the next will feature DSDS, after which we will feature a different activity from the field each quarter.

For the past several months I have received numerous inquiries as to the publication of Faceplate. This is your newsletter and the more information you send in, the better we can make it. It is intended to bring out a new issue each quarter in the future, so let us hear from you.

## DEEP SEA DIVING SCHOOL - LCDR G. E. ENRIGHT, USN, ASST. OFFICER IN CHARGE

The main news this issue is the large number of changes in both officer and enlisted instructors. As mentioned by the Officer in Charge, CDR MC NICOL and LCDR CARPENTER are no longer with us and our new Ass't. Officer in Charge is LCDR G. E. ENRIGHT. LTJG L. A. PAPI reported from USS YELLOWSTONE and relieved LTJG B. L. DELANEY who is now Officer in Charge at the Submarine Escape Training Tank, Pearl Harbor. CHBOSN BURNETTE, First Lieutenant, was retired in July and has been relieved by BOSN F. H. GUDGER from USS SUNEILD. CHBOSN REID (it came through just after he reported) is now Service Craft Officer, with CHBOSN UPCHURCH going to USS SALINAN (ATF-161). CHSHIPREPTECH C. H. RUSTIE has reported from Port Lyauvey and will relieve CHMACH SPARKMAN who has orders to USS WASP. ENS C. E. KOBYLARCZYK reported from NTC Great Lakes to fill the vacant billet of Salvage Instructor. CHBOSN T. H. MOSS has received orders to USS PROTEUS (AS-19), but may get new orders as he has just been informed that he was selected for LT. His relief, in any case, will be LTJG T. E. O'MALLEY, who is now on board USS SUBBIRD.

We won't attempt to list all the changes in enlisted instructors, but will just list who is here now. None are expected to leave in the near future, although there should be several additions to the list by the time the next issue goes to press - we hope there will be some additions. The present list is as follows:

ANDERSON, Richard E., Jr., DCC(DV)	SHIRCLIFFE, Albert C., BMC(DV)
BROWN, James C., BML(DV)	THOMAS, Donn E., BMC(DV)
BROWN, Kenneth L., BML(DV)	TIMMONS, Jerome M., SFC(DV)
CARPENTER, Clarence M., SFCA(DV)	WILLIAMS, Virgil (n), BMCA(DV)
EISSING, Frank E., SFC(DV)	AANERUD, Donald E., HMC(DV)
KENNEDY, James M., SFC(SDV)	BENNETT, Tommy J., HML(DV)
KILLE, Leon H., SFC(DV)	CHRISTENSON, Roger M., HMCA(DV)
LAHM, Jack F., SFCA(DV)	DAW, Arthur N., Jr., HML(DV)
MATTOX, Harold L., SFL(DV)	JACKSON, Bobby J., HML(DV)
MOHNEY, Gerald E., BML(DV)	RYDER, Warren A., HM2(DV)

### MORE ON EXTRAHAZARDOUS PAY

We have received copies of a great deal of correspondence addressed to BuPers on the subject of Extra-Hazardous Pay. As soon as possible, we will edit the various letters and prepare a digest of just what is happening currently in this field for inclusion in Faceplate. To stop the questions before they start, we will say, for now, that we don't have any special word on "forgiveness" of the checkages except what is already out in SECNAV NOTICE 7220 of 23 August 1960. We do have one request submitted under this Notice and will pass along the results when received.

### SELECTION OF DIVING CANDIDATES

The number of ineligible candidates reporting to Diving School for training is steadily increasing. Men are reporting who cannot pass the required physical examination, have claustrophobia, and have ARI-MECH combined scores far short of the minimum 105. There have been numerous

cases of Divers Second Class reporting for the Cross Training Course. All these cases have to be transferred again, or returned to their permanent duty station if on TAD, and this hits the Navy (which is you and me) where it hurts the most - right in the pocketbook. We all know that there are certain requirements which must be met before a man can be trained as a diver. If we start making exceptions to these requirements, we will soon start turning out a class of diver that would be dangerous to have around. Would you want an improperly-trained man working for you, or with you?? Please consult BuPers Inst. 1500.15D to make sure the man can be trained before you request quotas.

#### MORE ON SELECTION OF DIVING CANDIDATES

Medical Office

Recently a number of men have arrived at the Deep Sea Diving School for training either as First or Second Class Divers with various discrepancies in their preliminary screening. In one class of Second Class Divers alone, five persons (more than half the class) were found to have color deficiencies such that they could not pass the Farnsworth lantern test. Others have been rejected as psychiatrically unsuitable, and in at least two cases, should certainly have been screened in this regard prior to coming to the School. One had a history of "nervous trouble", the other a history of psychomotor epilepsy.

Probably the most overlooked screening procedure is the pressure and oxygen tolerance test which should, when possible, be performed prior to the applicants arrival at the School. The Training Officer has also stated that personnel frequently arrive at the School without a preliminary dive.

More attention to proper screening of personnel prior to their arrival at the Diving School would result in considerable savings to the Navy in both time and money.

#### SUBMARINE MEDICAL OFFICER STUDENTS

Medical Office

Another class of submarine medical officers will complete their training at the Deep Sea Diving School on 28 October 1960. This class is the largest in recent years, consisting of fifteen medical officers. They are:

LT Robert C. BORNHANN, MC, USN  
LT Paul J. CORCORAN, MC, USN  
LT Richard BRIGGS, MC, USN  
LT Clement H. DARBY, MC, USNR  
LT Thomas M. EVANS, MC, USN  
LT Kenneth J. FAUST, MC, USN  
LT Maxwell W. GOLDMAN, MC, USN  
LT Howard H. GREEN, MC, USNR

LT Thomas N. GYNN, MC, USNR  
LT Ira A. KISHNER, MC, USNR  
LT Hideaki NAKAYAMA, MC, JMSDF  
LT Kevin T. O'DONNELL, MC, USNR  
LT Arbeno RANARDJO, MC, I.N.  
LT Gordon J. WEIR, MC, USN  
LT James P. ZIMBLE, MC, USN

The third class of nine medical officers this year arrived on 17 October.

PERSONNEL

Since the last Faceplate there have been quite a few changes in the personnel situation, although most of the turnover is not due until next year. Most of the changes have been in the Administrative Department and involved "non-divers". Some of the later transfers are:

LTJG G. M. JANNEY, USNR, Assistant Project Officer has been released to inactive duty. No relief will be ordered.

WILLIAMS, G. D., EN2(DV) to USS HALFBEAK (SS-352)  
ANDERSON, J. W., BM2(DV) to USS TRINGA (ASR-16)  
GWINN, R. L., MML(DV) to SHIPPEFFAC, GUAM  
TRIPP, J. E., DC1(DV) to USS PENGUIN (ASR-12)  
GEDVES, G. C., ET1(DV) to USS MARKAB (AR-23)

To keep old shipmates advised of the divers in the Unit, here is our latest diver roster:

CDR N. E. NICKERSON, USN	ADDU OFFICER IN CHARGE
LCDR E. W. CARPENTER, USN	ASST. OFFICER IN CHARGE
LCDR, J. L. GREENE, USN	PROJECT OFFICER
CAPT M. K. HOLLER, USN (MC)	SENIOR MEDICAL OFFICER
LT P. G. LINAWEAVER, JR., USN (MC)	SUBMARINE MEDICAL RESEARCH
LTJG R. J. KIESSLING, USNR (MSC)	EXPERIMENTAL PSYCHOLOGIST
CWO L. L. SMITH, USN (MSC)	MEDICAL TECHNICAL ASSISTANT

POWELL, B. L., TMC(DV)	SENIOR MASTER DIVER
STEPHENS, C. W., BMC(DV)	MASTER DIVER

ANGLIN, F. B., DC1(DV)	MICHEISEN, C. E., HML(DV)
AVILA, R. J., GML(DV)	MILNE, I. R., BMC(DV)
BRANDENBURG, H. A., MRC(DV)	NAQUIN, J. C., SF1(DV)
BULLOCK, E., BM3(DV)	PARKHURST, G. E., JR., EMC(DV)
CARROLL, R. C., SF1(DV)	SIROTNIAK, J. J., BM2 (DV)
JAMES, T. W., HML(DV)	TAPLER, W. L., ET2(DV)
JOSENHANS, F. E. JR., SF1(DV)	VAIL, J. R., HMC(DV)
MALLDER, C. R., SF1(DV)	ZIEGLER, H. C., BML(DV)

On 16 November CARROLL will don the "hat" of SFC and BULLOCK is going back up the line with BM2.

DIVERS PAY

The mechanics necessary to obtain any type of Congressional legislation are necessarily long and involved. When viewed by those of us not familiar with such matters, we sometimes are too quick to criticize.

However, those who are responsible for the writing of this sheet believe that everything possible is being done to get the (not so newly) proposed "divers pay" before the next session of Congress.

MEDICAL

CAPT M. K. HOLLER, MC, USN

CLOSED AND SEMI-CLOSED CIRCUIT CARBON DIOXIDE ABSORBENTS

The Experimental Diving Unit's interest in carbon dioxide absorbents for field use in scuba continues. And with the MK 5 units now available for full scale use the subject has taken on a renewed interest. It appears, from talks with personnel visiting the area, cross trainees, etc., that many people have a misconception regarding the causticity of caustic vs non-caustic absorbents. It should be emphasized that the water in a flooded canister is irritating and caustic to the mucous membranes, regardless of the type absorbent used. It is true that caustic absorbents produce significantly more caustic solution than non-caustic absorbents, but it must be remembered that both are, to some degree, caustic. The term non-caustic absorbent in this respect is somewhat misleading. In spite of the fact that solution of carbon dioxide absorbents used in scuba are caustic, significant danger to the underwater swimmer from this source is not anticipated, because exposure of the diver to caustic solution from the canister should be very infrequent and result only from improper care and/or malfunctioning of the equipment when it does occur. Termination of the dive immediately will prevent any significant discomfort or permanent harmful effects to the swimmer.

Experiments conducted at this activity (Research Report 1-60, dated 6 November 1959) have conclusively shown that attempts to conserve absorbent material by reducing the size of the loads in the canister, in the case of short dives, etc., is very dangerous and should not be permitted under any circumstances.

EQUIPMENT NEWS

LCDR J. L. GREENE, USN, PROJECT OFFICER

ANCHOR PLUG ON AMPLIFIER AND LIFELINE CABLE

A recent failure report has been received from a field activity and is quoted in part:

"While testing and inspecting a new divers' lifeline and telephone cable prior to being put in service, a failure of the anchor plug was encountered. The cable pulled free of the connector when subjected to a steady but light strain, hand applied of approximately 200-300 pounds. Investigation revealed that there was no lead present in the unlaidd strands of the core cable".

The importance of this failure cannot be over emphasized. In view of this failure it is strongly recommended that the Jackplug be disassembled in accordance with Section 2.3.2 (31) of the Diving Manual and the anchor plug inspected to insure that lead is properly inserted.

The Bureau of Ships has been advised of this failure and is taking action to eliminate the unsatisfactory lifelines from stock, but still, where a diver's life depends on this equipment, the time involved in checking out the anchor plug will be well spent.

## NON-RETURN VALVE

The standard non-return valve which is now in stock is a radical change in design. The Deep Sea Diving School obtained ten of these valves through normal supply channels. It was immediately determined that they are unsatisfactory in their present configuration. The primary fault is that the "O" ring blows out of the groove in which it is seated and thereby no non-return seal is made. An additional problem is that the present clearance and spring on the valve stem causes excessive chatter over a wide range of flow. Several new stems were turned out at the Unit with various clearances, springs, and "O" ring grooves. The following drawing shows the optimum dimensions and configuration to eliminate the problem:

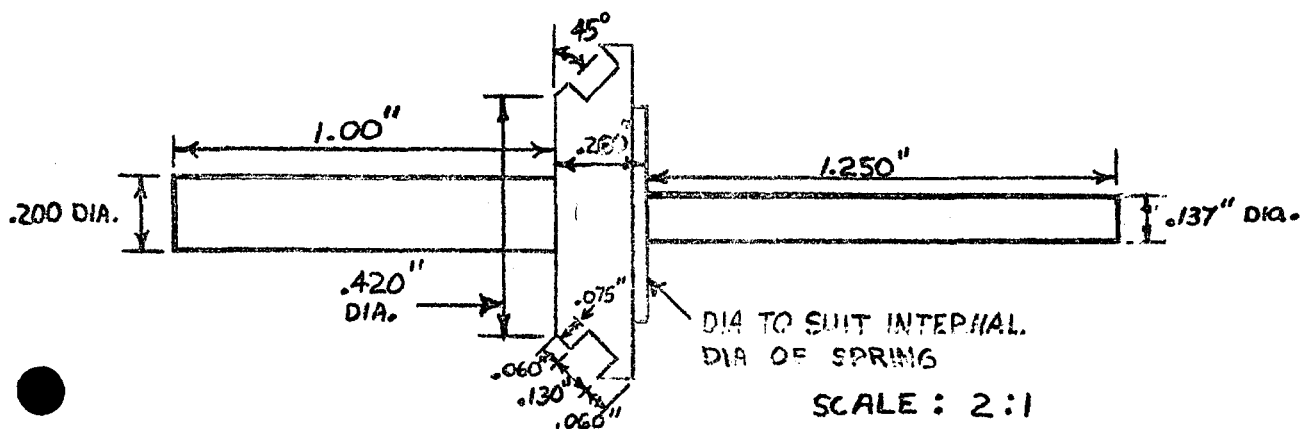

The dimensions shown on the valve stems may vary with the individual valve which is being modified. It is strongly recommended that the guides in the valve body be hand reamed and that the valve stems be made to fit with less than 5/1000 clearance. Further, a new spring must be used. The best of several tried here was 1" long, 7/16" diameter, and a spring constant of from 3 to 4 lbs/inch of compression. (A spring of similar characteristics can be substituted). The new size "O" ring is 1/2" x 1/8" for which the drawing shows a rectangular groove rather than the shallow "V" of the issued stem. The diameter of the shoulder on the right side of the valve seat is determined by the internal diameter of the spring.

This recommended modification is to be considered only an interim measure. The Unit now has under test at the Deep Sea Diving School a modified commercial check valve which, so far, promises to be a major step in eliminating the ever present problem of chatter. Naturally, it will be some time before this new concept will be fully evaluated, but it looks like a major step forward.

## FIELD ACTIVITY NEWS

UNDERWATER SWIMMER'S SCHOOL KEYWEST, FLORIDA

LCDR KEN FLOOT  
Officer in Charge

As you know, the Department of Defense is becoming very much concerned with the expenditure of travel funds. You and I, as taxpayers, should be equally concerned. U/WSS has received a number of candidates (from Alaska, Hawaii, Timbuctoo, etc.) who for various reasons were not qualified in accordance with current directives. I am sure that other diver training activities have experienced similar problems. In the screening of candidates for any type of diver training, all of you at fleet and field diving activities can help tremendously. Candidates come to you for the required recompression chamber tests, interview by a qualified diving officer and "dunking" in a full diving rig. I would suggest that you insist on seeing a NAVMED Form 88, completed except for the chamber tests, before you conduct the latter. Look these forms over carefully. We have been getting a lot of over age candidates. The interview and the claustrophobia test are very important and may be we could all be a bit more conscientious in this area. Of course we all like to be "Good Joes" and we hate to hold a man back, but let's face it, some people just are not cut out for diving---scuba, hard-hat, or what have you. It would certainly be much better to screen out the misfits before a lot of travel funds and man-days are expended. I realize that no screening system will prove 100 % effective, but I sincerely believe that we could improve quite a bit. Our later scuba class had an attrition rate of 33%. In most cases these failures should never have been ordered to diver training.

### Deep Sea Divers School and Experimental Diving Unit Visitations

Professor Sydney SUNDERLAND, MC, BS, DSc, FRACP, FRACS, FAA,  
Honorable Professor of Anatomy and Histology and  
Dean of the Faculty of Medicine, University of Melbourne,  
Australia. Member Australian Defense Research and Development Policy Committee, Member Australian Medical Services Committee.

Mr. Carvel W. REYNO, Technical Officer, Naval Research Establishment  
of the Defense Research Board of Canada

The Surgeon General of the Thailand Navy